

Quantum corpo lampada - 5425

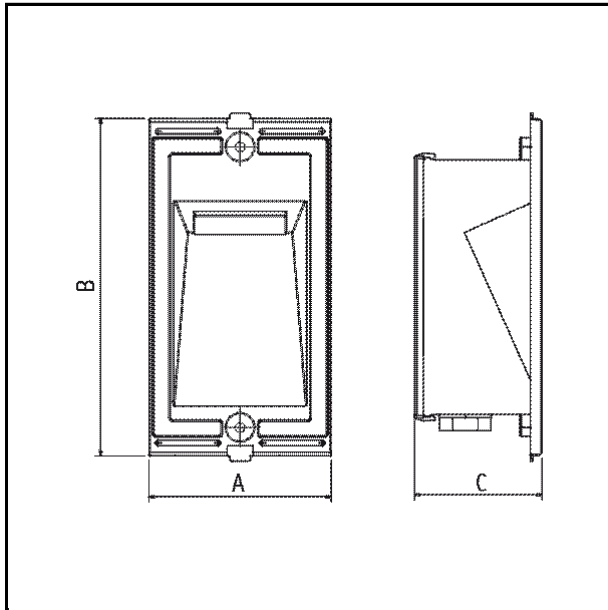

COD.	5425
LAMPADA	 LED
W	3,2W
V	220-240V
IP	IP 65 
CLASSE	 Classe II
IK	IK10 (20 joules)
CERTIFICAZIONE	
CONFORMITÀ	EN 60 598-1:08+A11:09
COLORI	
CLASSE ENERGETICA	



SPECIFICHE

- Corpo in policarbonato
- Viti inox
- A montare su scatola 4 moduli (per interno)
- A montare su controcassa Goccia 5481 (per esterno)
- Sicurezza fotobiologica: gruppo di rischio 0 in accordo alla norma EN 62471:08
- Led Citizen 3,2 W incorporato
- 265 lumen complessivi
- Tonalità: 3500K. Indice resa cromatica 85
- Vita: 50.000 h con decadimento max del 30%
- 220-250 V, 50-60 Hz, alimentatore 350 mA incorporato

DIMENSIONI

A 70 mm
B 130 mm
C 49 mm

Stampa creata il 05/12/2015 10:09

GOCCIA ILLUMINAZIONE s.r.l.

via E.Fermi, 59/65 | 25020 Poncarale (BS) Italy
Tel. +39.030.26.40.761 r.a. | Fax +39.030.26.40.271
www.goccia.it | info@goccia.it