



Voltage
Tensione
 220 - 240 V

Frequency
Frequenza
 50...60 Hz

Potenza
Power
 3 - 7 W

Supply current
Corrente di alimentazione:
 20 mA

Operating time
Autonomia:
 1-3 h

Charge time
Tempo di ricarica:
 24 h

ta °C: 0...+60

tc °C: 80

Reference Norms
Norme di riferimento:

EN 55015
 EN 60598-2-22
 EN 61000-3-2
 EN 61347-2-13
 EN 61347-2-7
 EN 61547

- Class II protection against electric shock for direct or indirect contact.
- Instant emergency operation at mains failure.
- Maintained or not maintained operation (maintained operation suitable with electronic drivers or dimmable electronic drivers).
- Multi-power dimmable version DIP-SWITCH, constant current or constant voltage to power LED to LED modules.
- "High temperature" Ni-Cd batteries.
- Charge indicator with LED.
- Protection device against extensive discharge.
- "Rest mode" facility with remote control device.

Technical data

- Length battery cable: 280 mm / 11".
- Length LED cable: 350 mm / 13,8".
- LED mounting hole: Ø 9 mm / 0,35".
- Supply current: 20 mA max.
- Terminal blocks max. connection size: 1,5 mm² / AWG15.
- Max distance between driver and lamp: 2 mt / 6 ft.

- Protetto in classe II contro le scosse elettriche per contatti diretti e indiretti.
- Intervento istantaneo ad ogni mancanza di rete.
- Funzionamento in sola emergenza o in luce continua (luce continua in abbinamento con alimentatori elettronici e alimentatori elettronici dimmerabili).
- Regolazione con DIP-SWITCH, per power LED a corrente costante o per moduli LED a tensione costante.
- Batterie al Ni-Cd "alta temperatura".
- Indicatore di ricarica a LED.
- Dispositivo di protezione contro le scariche prolungate.
- Possibilità d'inibizione in "modo riposo" con telecomando esterno centralizzato.

Dati tecnici

- Lunghezza cavo batteria: 280 mm / 11".
- Lunghezza cavo LED: 350 mm / 13,8".
- Foro di montaggio LED: Ø 9 mm / 0,35".
- Corrente di alimentazione: 20 mA max.
- Portata morsettiera: 1,5 mm² / AWG15.
- Distanza massima dall'alimentatore dalla lampada: 2 m / 6 ft.

Code Codice	ELDN T (1h)	ELDN T-3 (3h)	signal LED	Ni-Cd BATTERY			Battery case	
				7,2 V - 1,6 Ah COMPACT - COMPATTI	7,2 V - 4 Ah COMPACT - COMPATTI	2x 3,6 V - 4 Ah LINEAR - LINEARE	BOX 1h	BOX 3h
123010	✓		✓	✓				
123010K	✓		✓	✓			✓	
123010/3		✓	✓			✓		
123010/3K		✓	✓		✓			✓
123010NB	✓		✓					
123010/3NB		✓	✓					

Emergency LED drivers
 Alimentatori LED per illuminazione d'emergenza

8.



Emergency light KIT for power LED and LED modules KIT per luce d'emergenza per power LED e moduli LED

Made in Europe



Weight - Peso: gr. 185 / 6,52 oz.
 Pcs - Pezzi 1

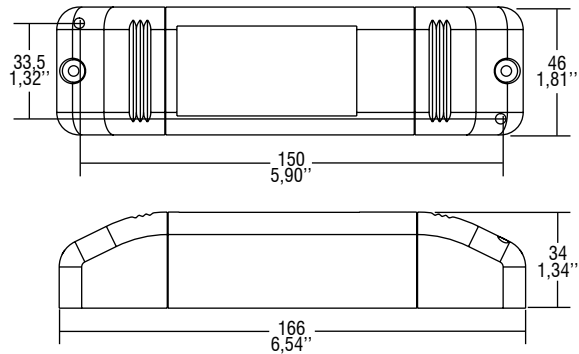

Wiring diagrams - Schemi di collegamento

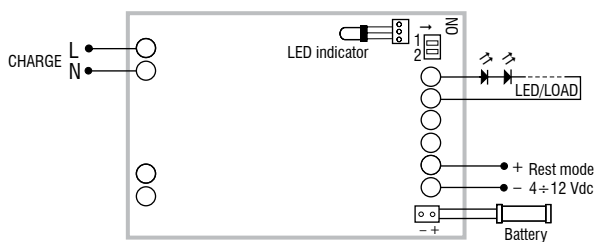

Non-maintained (emergency only) diagram
Collegamento non permanente (solo emergenza)

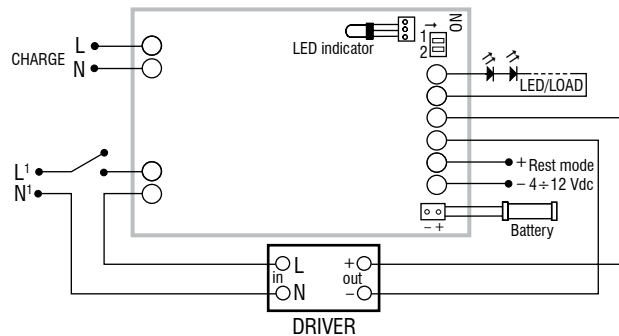

Maintained with external electronic driver diagram
Collegamento permanente (illuminazione ordinaria)

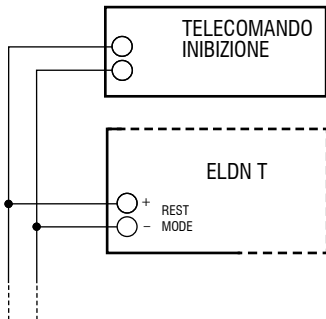

Remote control device diagrams
Collegamento con telecomando esterno centralizzato

Remote control device

It allows both to switch off the emergency lamps during emergency mode. The rest mode is automatically resetted when mains voltage is restored. This remote control device can be installed so as to operate several emergency units at the same time.

Con telecomando esterno centralizzato

Permette lo spegnimento delle lampade durante il funzionamento in emergenza. Al rientro della tensione di rete il sistema si predisporrà ad un nuovo intervento in emergenza.

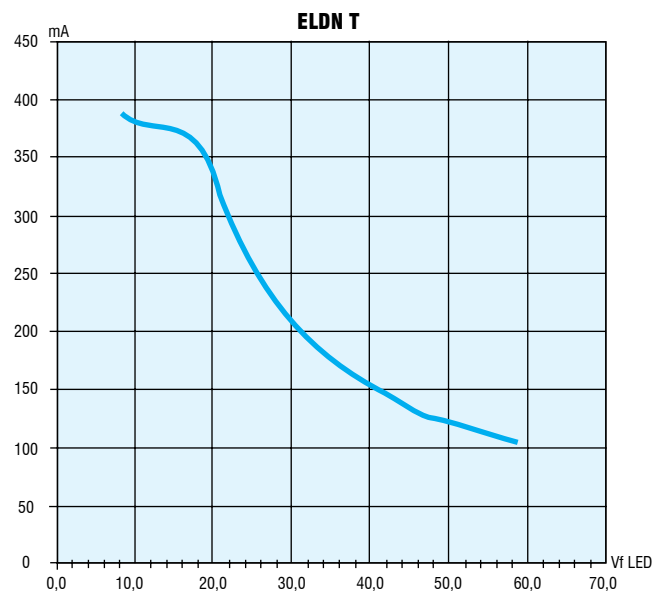

DIP-SWITCH	Working voltage during emergency (V _L) Tensione di lavoro in emergenza (V _L)	Output current during emergency (I) Corrente in uscita in emergenza (I)	n° LED max.	Power max. for LED modules Potenza max. per moduli LED
A	9...12 V	350 ± 10%	3/4	24 W
B	9...24 V	350...250mA	7/8	30 W
C	9...46 V	350...125mA	12/14	-
D	9...58 V	350...100mA	17/18	-